

BB 50

Battery Booster | 50 A | 90 - 560 Ah | 24 to 24 V



Electrical Specifications

Battery Nominal Voltage (DC)	24V
Battery nominal capacity	90 - 560Ah
Starter battery nominal capacity min.	100Ah
“Board I” max. charge current	50A
Input voltage range “Start II”	20 - 32V
Input overvoltage disconnection “Start II” , max.	33V
Activation control input “D+”	16 - 32V
Main battery overvoltage protection	31V
Stand-by current	24mA
ECE R10 conformity	 10R06/01*3837*00

Mechanical Specifications

Measurements (L x W x H)	240 x 190 x 70 mm
Weight	1.6kg
Temperature range	-20 to 50°C
Ambient conditions	max. 95% humidity, no condensation
Optional accessories	Charge monitor, Bluetooth adapter, App display
Input “T T” for battery temperature sensor “Board I”	Yes
“Ss-” “Ss+” inputs for sensor cables “-” and “+” for Battery “Board I”:	Yes

Measurements

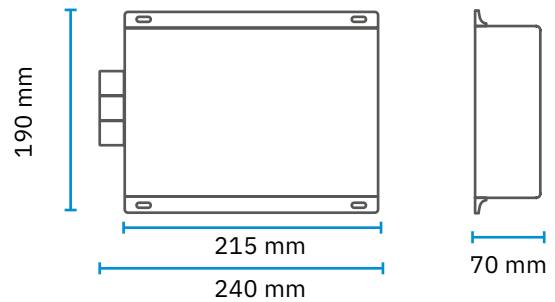

Charging Characteristics

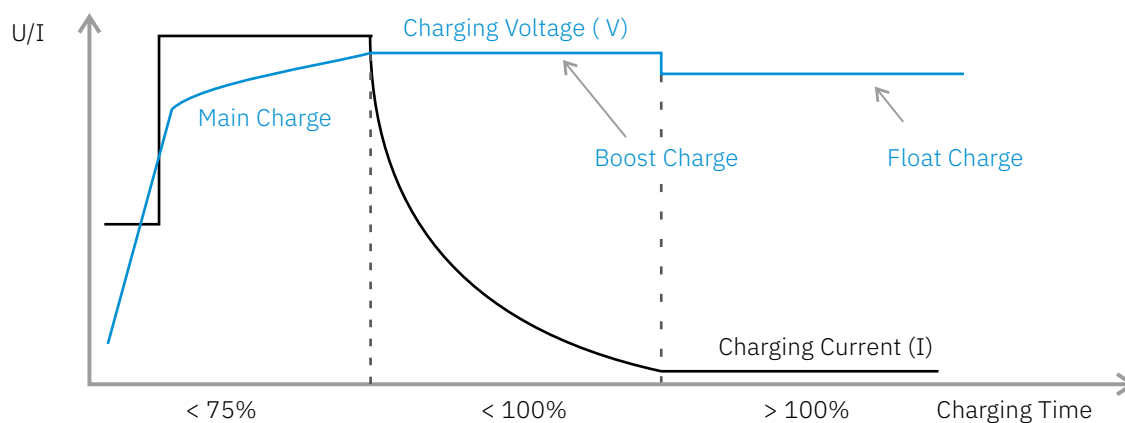

Adjustable for battery types:

- Lead acid
- AGM
- Gel
- LiFePO₄