

# BB 60

Battery Booster | 60 A | 90 - 560 Ah | 12 to 12 V



## Electrical Specifications

Battery Nominal Voltage (DC)	12V
Battery nominal capacity	90 - 560Ah
Starter battery nominal capacity min.	100Ah
“Board I” max. charge current	60A
Input voltage range “Start II”	10,5 - 16V
Input overvoltage disconnection “Start II” , max.	16,5V
Activation control input “D+”	8 - 16V
Main battery overvoltage protection	15,5V
Stand-by current	24mA
ECE R10 conformity	 10R06/01*3837*00

## Mechanical Specifications

Measurements (L x W x H)	240 x 190 x 70 mm
Weight	1.54kg
Temperature range	-20 to 50°C
Ambient conditions	max. 95% humidity, no condensation
Optional accessories	Charge monitor, Bluetooth adapter, App display
Input “T T” for battery temperature sensor “Board I”	Yes
“Ss-” “Ss+” inputs for sensor cables “-” and “+” for Battery “Board I”:	Yes

## Measurements

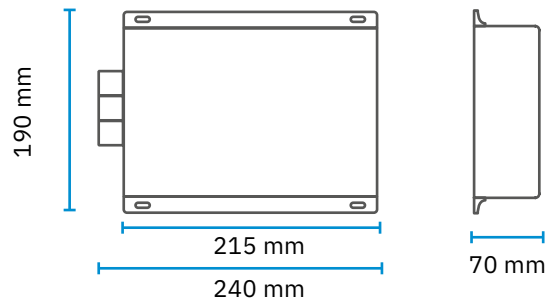

## Charging Characteristics

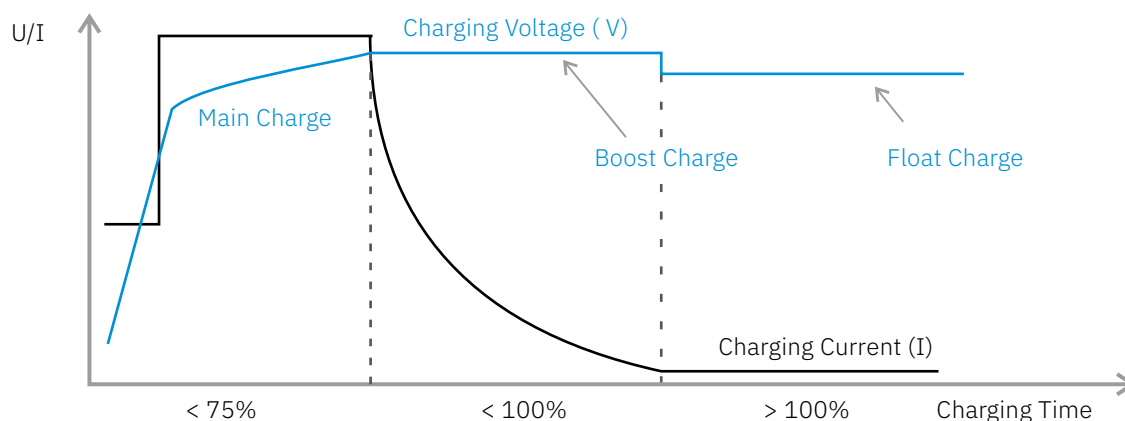

Adjustable for battery types:

- Lead acid
- AGM
- Gel
- LiFePO<sub>4</sub>